



Parade

 To secure that the walking-aid will function safely for the user, once per year review of the walking-aid should be done. Therefore is the following interventions recommended.

Cleaning

Regular cleaning with a mild cleanser is recommended. Machine washing, 60 degrees for 10 minutes, can be used. Avoid using a pressure washer directly to the bearings.

Note! Do NOT use thinner, petrol or other solvents.

Post treatment

After washing, all connections, tight spaces and drainage holes should be blown dry and sprayed with thin oil. If degreaser is used, should the moving parts be lubricated.

The Paint

Control damages to the paint. To prevent corrosion, improve scratches. Touch-up paint can be ordered from Human Care AB.

Pipe frame

Control weldings and screw attaches. If the corrosion is extensive shall the rollator be replaced.



Handle on rollators after Jan 22, 2015

Handle

Must be fixed. Make sure the handle pipes can be pushed down to the chassis. Change the grip if needed.

Note: Rollators with production date after Jan 22, 2015 have handle kit with part no 89055. Rollators produced earlier can be upgraded with 89055 (see spare part list and drawing).



Handle on rollators prior Jan 22, 2015

Brakes

Control that both brakes and parkingbrakes are working. Wires should be intact and stapped to the chassis.

Wing nut
Control function.

Reflectors
Make sure the reflectors are still there and visible.

CE-marking
Make sure that the CE-marking is still there and readable.

Wheels
Make sure the wheels are not worn-out and are spinning easily without any noise.

Lubrication
Gatebushings and hinges should be working without any noise. Lubricate when needed.

Front forks
Make sure that the ball bearings is firmly attached. Check the front fork inertia by allowing the wheel to swing between 3 and 9 o'clock. Both wheels shall swing 3 to 10 times with max 2 swings difference between each wheel.

Folding mechanism
Should be intact and the locking should function.

Seat
Make sure the seat is kept in place and screws are tightened.

Stability
Control that all wheels are steadily on the ground and that there are no chassis distortion.

Test driving
Make a final control by test driving.



RECONDITIONING MANUAL

Standard handle on rollators
produced after Jan 22, 2015
(spare part for earlier version)

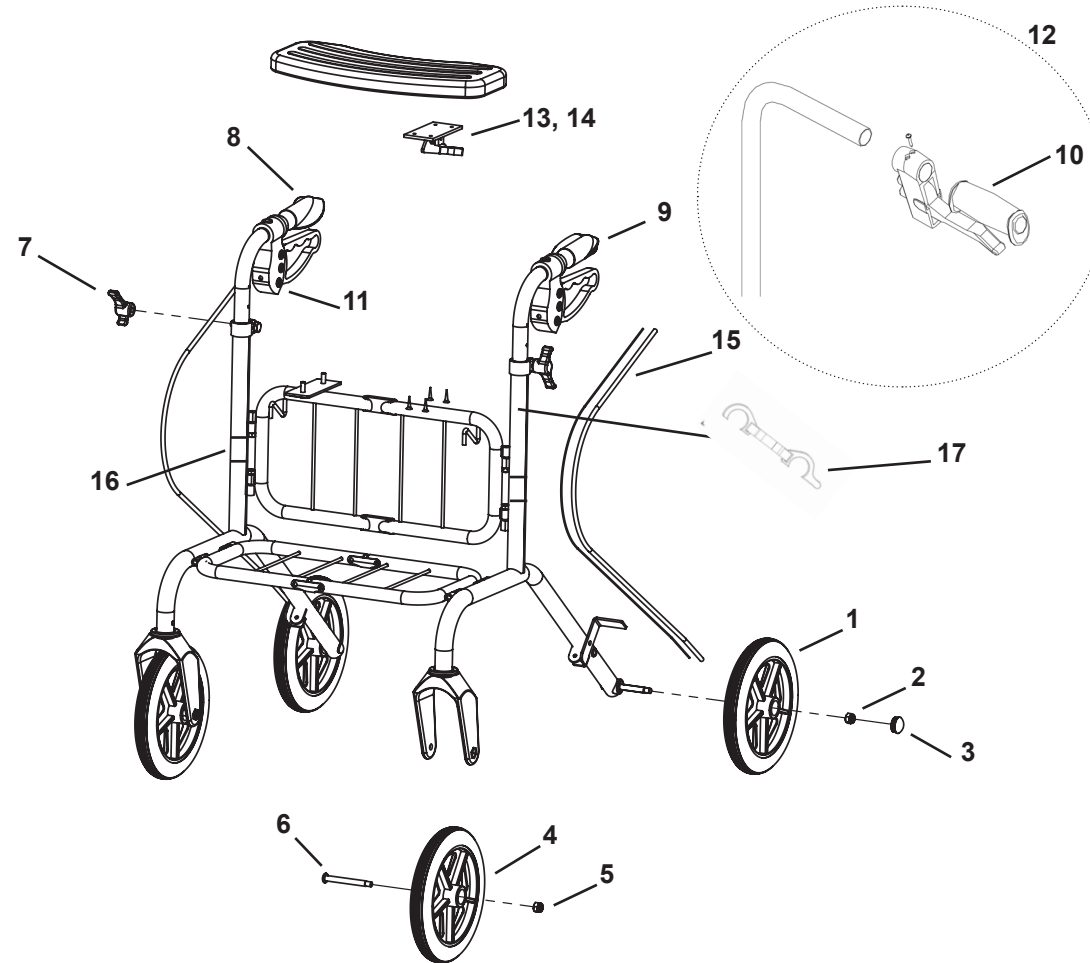

• Årstaängsvägen 21C, SE-117 43 Stockholm, Sweden •
• Tel. +46(0)8 - 510 132 00 • Fax +46(0)8 - 665 35 10 •
• www.humancaregroup.com •